



INSTALLATION AND SERVICE MANUAL



iQool-C2MSC3PMS
iQool-C3MSC5PMS

1 x 18,000 BTU and 1 x 12,000 BTU Cassette units
2 x 18,000 BTU and 1 x 12,000 BTU Cassette units

SMART WiFi CONTROLLED CEILING MOUNTED MULTI CASSETTE AIR CONDITIONER

Thank you for choosing an electriQ Air Conditioner
Please read this user manual before using this innovative
Air Conditioner and keep it safe for future reference.

SETTLING IN OK?

We hope this has been helpful to you.

We would love to see how you're getting on with your new purchase, so please share any snaps you have on the platform of your choice below.

Our community awaits your uploads - Snap, tag and hashtag away!



@electriQUK

#electriQUK

WE'RE HERE TO HELP

Should you have any problems or questions with your purchase, please contact a member of our customer service team.

☎ 0330 390 3061

✉ support@electriQ.co.uk

Mon-Fri | 9am to 5pm

Unit 2A, Trident Business Park,
Neptune Way, Leeds Road,
Huddersfield, HD2 1UA

CONTENTS

SAFETY WARNINGS	4
SYSTEM DIAGRAM	12
PARTS LIST	14
SELECTING THE INSTALLATION LOCATION	15
INDOOR UNITS	15
OUTDOOR UNIT	16
TECHNICAL INFORMATION FOR INSTALLATION	17
TOOLS RECOMMENDED FOR INSTALLATION	18
INSTALLATION	19
INDOOR UNITS	19
OUTDOOR UNIT	25
TEST OPERATION	29
ELECTRICAL WIRING DIAGRAMS	31
TROUBLESHOOTING AND SELF DIAGNOSIS	34
TECHNICAL SPECIFICATION	37
SUPPORT	38

SAFETY WARNINGS



CAUTION: RISK OF FIRE



READ THE OPERATING
INSTRUCTIONS



READ THE TECHNICAL MANUAL

GENERAL INSTRUCTIONS

- Before commencing work on this appliance, the safety instructions from this manual must be read and understood. During the work these instructions must be fully adhered to. If in doubt, please contact the manufacturer for assistance.
- The installer must ensure they are suitably qualified and insured for the work they are carrying out. The manufacturer accepts no liability for damage or injury caused due to failure to follow the instructions.
- This appliance comprises of multiple indoor units connected to a single outdoor unit. The indoor slim evaporators are designed exclusively for indoor installations while the external condenser can be installed outside while still away from flood water or snow line.
- Always place the unit on a dry and stable surface. Install the outdoor unit on a wall with wall-mounting brackets or fix to a floor slab with floor mounting slab bolts or brackets.
- Installation must be in accordance with the regulations of the country where the unit is used.
- This appliance is intended for permanent installation into a fixed structure, and should not be installed on vehicles.
- The outdoor part of the air conditioner unit must always be stored and transported upright, otherwise irreparable damage may be caused to the compressor; if in doubt we suggest waiting at least 24 hours before starting the unit.
- If you are in any doubt about the suitability of your electrical supply have it checked and, if necessary, modified by a qualified electrician.
- This air conditioner has been tested and is safe to use. However, as with any electrical appliance - use it with care.
- Disconnect the power before dismantling, assembling or cleaning.
- Never connect the unit to an electrical outlet using an extension cord. Both the indoor and outdoor units must be hardwired by a qualified electrician.
- Never operate this appliance if the cord is damaged. Ensure the power cord is not stretched or exposed to sharp objects or edges.
- A damaged supply cord should be replaced by the manufacturer or a qualified electrician in order to avoid a hazard.
- Avoid touching any moving parts within the appliance.
- Never insert fingers, pencils or any other objects through the guard.
- This appliance is not intended for use by persons (including children) with reduced physical, sensory or mental capabilities. It is also not intended for use by those with a lack of experience and knowledge, unless they have been given supervision or instruction concerning the use of the appliance by a person responsible for their safety. Do not leave children unsupervised with this appliance.
- Any service other than regular cleaning or filter replacement should be performed by an authorised service representative or a qualified air conditioning engineer. Failure to comply could result in a voided warranty.
- This air conditioner is intended for cooling / heating a room to a suitable level for human comfort, and should not be used for any other purpose such as cooling food.
- The indoor units should not be installed in laundry or wet rooms.
- Diagrams and pictures provided within the installation and user manuals are for guidance only. Due to continual product development, if there is any variance between the manual and the product received, the information provided on the product should be followed.
- The manufacturer and retailer cannot be responsible for the interpretation of this information, nor can it assume any liability in connection with its use.
- The equipment is designed for domestic or office use and we are not making any endorsements for use in industrial or maritime environment.

SAFETY WARNINGS

- If the appliance is installed, used or stored in an unventilated room, the room must be such as to prevent stagnation of possible leaks of refrigerant gas as there could be a danger of fire or explosion should the refrigerant come into contact with electric heaters, stoves or other sources of ignition.
- Do not place near sources of heat, vapours, industrial machine oil or other flammable gases.
- R32 refrigerant gas complies with European environmental directives.
- R32 has a GWP (Global Warming Potential) of 675.
- The air conditioners contain the following quantity of refrigerant gas:

iQool-C2MSC3PMS	1600g
iQool-C3MSC5PMS	3000g

- R32 is classed as flammable and as such naked flames and sources of ignition should be kept a safe distance from the unit.
- Do not install or store in an unventilated space with an area smaller than shown in the table below per system. Smaller room sizes may be suitable if other safety measures are implemented and a risk assessment conducted

iQool-C2MSC3PMS	4m ²
iQool-C3MSC5PMS	5.74m ²

- The above figures are based on the refrigerant charge with the supplied 5 metre pipe kit, and should be adjusted according to pipe length.
- Refrigerant gas may be odourless.
- Do not use the product and contact the retailer for advice, if damage has occurred to the unit which may have compromised the refrigerant system.
- High-frequency waves generated by radio equipment, welders and medical equipment will interfere with the normal operation of the unit.
- Install this device only when it complies with local/national legislation, ordinances and standards.
- Check the mains voltage and frequency. This unit is only suitable for an earthed electrical supply, connection voltage 220-240 V~ / 50 Hz. The information, specifications and parameter are subject to change due to technical modifications or improvement without any

prior notice. The accurate specifications are presented on the nameplate label.

- Please read this installation manual completely before installing the product.
- Installation work must be performed in accordance with all European, national and / or local directives and standards and must be done by authorised personnel only.
- Always make sure to wear the correct personal safety protections such as protective eyewear, gloves, ear protection etc.
- This air conditioner contains a refrigerant and can be classified as pressurised equipment. Therefore, we advise to contact an authorised air conditioning engineer for installation and maintenance of the air conditioner.
- The air conditioner must be inspected and serviced on an annual basis by an authorised air conditioning engineer.

Checks to the area

Prior to beginning work on systems containing flammable refrigerants, safety checks are necessary to ensure that the risk of ignition is minimised. For repair to the refrigerating system, the following precautions shall be complied with prior to conducting work on the system.

Work procedure

Work shall be undertaken in a controlled procedure so as to minimise the risk of a flammable gas or vapour being present in the air while the work is being performed.

General work area

All maintenance staff and others working in the local area shall be instructed on the nature of work being carried out. Work in confined spaces shall be avoided. The area around the workspace shall be sectioned off. Ensure that the conditions within the area have been made safe by control of flammable material.

Checking for presence of refrigerant

The area shall be checked with an appropriate refrigerant detector prior to and during work, to ensure the technician is aware of potentially flammable gases in the atmosphere. Ensure that the leak detection equipment being used is suitable for use with flammable refrigerants, i.e. non-sparking, adequately sealed and intrinsically safe.

SAFETY WARNINGS

Presence of fire extinguisher

If any hot work such as brazing or soldering is to be conducted on the refrigeration equipment or any associated parts, appropriate fire extinguishing equipment should be available in close proximity to the work area. This must be of a dry powder or CO₂ type.

No ignition sources

No person carrying out work in relation to a refrigeration system which involves exposing any pipe work that contains or has contained flammable refrigerant shall use any sources of ignition in such a manner that it may lead to the risk of fire or explosion. All possible ignition sources, including smoking, should be kept sufficiently far away from the site of the work during the time it is possible flammable refrigerant could be released to the surrounding space. Prior to work taking place, the area around the equipment is to be surveyed to make sure that there are no flammable hazards or ignition risks. "No Smoking" signs must be displayed.

Ventilated area

Ensure that the area is adequately ventilated before breaking into the system or conducting any hot work. A degree of ventilation must continue during the period that the work is carried out. The ventilation should safely disperse any released refrigerant and preferably expel it externally into the atmosphere.

Checks to the refrigeration equipment

Where electrical components are being changed, they must only be exchanged for components confirmed to be compatible by the manufacturer. At all times the manufacturer's maintenance and service guidelines must be followed. If in doubt consult the manufacturer's technical department for assistance. The following checks must be applied to installations using flammable refrigerants:

1. The charge size is in accordance with the room size within which the refrigerant containing parts are installed;
2. The ventilation machinery and outlets are operating adequately and are not obstructed;
3. If an indirect refrigerating circuit is being used, the secondary circuit shall be checked for the presence of refrigerant;

4. Marking to the equipment continues to be visible and legible. Markings and signs that are illegible shall be corrected;

4.5. Refrigeration pipe or components are installed in a position where they are unlikely to be exposed to any substance which may corrode refrigerant containing components, unless the components are constructed of materials which are inherently resistant to being corroded or are suitably protected against being so corroded.

Checks to electrical devices

Repair and maintenance to electrical components shall include initial safety checks and component inspection procedures. If a fault exists that could compromise safety, then no electrical supply shall be connected to the circuit until it is satisfactorily dealt with. If the fault cannot be corrected immediately but it is necessary to continue operation, an adequate temporary solution shall be used. This shall be reported to the owner of the equipment so all parties are advised.

Initial safety checks shall include:

- That capacitors are discharged: this shall be done in a safe manner to avoid possibility of sparking;
- That there no live electrical components and wiring are exposed while charging, recovering or purging the system;
- That there is continuity of earth bonding.

REPAIRS TO SEALED COMPONENTS

During repairs to sealed components, the electrical supply must be disconnected from the equipment being worked upon prior to removal of the cover. If it is absolutely necessary to have an electrical supply to equipment during servicing, a permanently operating form of leak detection must be located at the most critical point to warn of leakage.

Particular attention must be paid to the following to ensure that the unit is not hazardous:

1. The unit is not altered in such a way that the level of protection is affected. This shall include damage to cables, excessive number of connections, terminals not made to original specification, damage to seals, incorrect fitting of glands, etc.
2. Ensure that apparatus is mounted securely.

Formatted: List Paragraph, Justified, Indent: Left: 0.5 cm, Hanging: 0.5 cm, Numbered + Level: 1 + Numbering Style: 1, 2, 3, ... + Start at: 1 + Alignment: Left + Aligned at: 1.27 cm + Indent at: 1.27 cm

Formatted: Justified, Indent: Left: 0.5 cm, Hanging: 0.5 cm, Numbered + Level: 1 + Numbering Style: 1, 2, 3, ... + Start at: 1 + Alignment: Left + Aligned at: 1.27 cm + Indent at: 1.27 cm

SAFETY WARNINGS

3. Ensure that seals or sealing materials have not degraded such that they no longer serve the purpose of preventing the release of refrigerant.
4. Replacement parts must be in accordance with the manufacturer's specifications.

NOTE: The use of silicon sealant may inhibit the effectiveness of some types of leak detection equipment. Intrinsically safe components do not have to be isolated prior to working on them.

REPAIR TO INTRINSICALLY SAFE COMPONENTS

Do not apply any permanent inductive or capacitive loads to the circuit without ensuring that this will not exceed the voltage and current permitted for the equipment in use.

The test apparatus shall be of the correct rating. Replace components only with parts specified by the manufacturer. The use of other parts may result in the ignition of refrigerant in the atmosphere from a leak.

CABLING

Check that the cabling will not be subject to wear, corrosion, excessive pressure, vibration, sharp edges or any other adverse environmental effects. The check shall also take into account the effects of aging or continual vibration from sources such as compressors or fans.

DETECTION OF FLAMMABLE REFRIGERANTS

Under no circumstances can potential sources of ignition be used in the detection of refrigerant leaks. A halide torch (or any other detector using a naked flame) must not be used.

LEAK DETECTION METHODS

Electronic leak detectors can be used to detect flammable refrigerants. Before use you must ensure that the detector is of a suitable sensitivity and the detector must be calibrated in a refrigerant free area. Ensure that the detector is not a potential source of ignition and is suitable for the type of refrigerant used. Leak detection equipment shall be set at a percentage of the LFL of the refrigerant and shall be calibrated to the refrigerant employed and the appropriate percentage of gas (25 % maximum) is confirmed.

Leak detection fluids are suitable for use with most refrigerants but the use of detergents containing chlorine shall be avoided as the chlorine may react with the refrigerant and corrode the copper pipework. If a leak is suspected, all naked flames must be removed/extinguished.

If a leakage of refrigerant is found which requires brazing, all of the refrigerant must be recovered from the system, or isolated (by means of shut off valves) in a part of the system remote from the leak. Oxygen free nitrogen (OFN) should then be purged through the system both before and during the brazing process.

REMOVAL AND EVACUATION

When breaking into the refrigerant circuit to make repairs or for any other purpose conventional procedures must be followed. However, it is important that flammability is also considered. The following procedure must be adhered to:

1. Remove refrigerant;
2. Purge the circuit with inert gas;
3. Evacuate;
4. Purge again with inert gas;
5. Open the circuit by cutting or brazing.
6. The refrigerant charge shall be recovered into the correct recovery cylinders.
7. The system shall be "flushed" with OFN (Oxygen Free Nitrogen) to render the unit safe.

The unit may need to be flushed several times. Compressed air or oxygen must not be used for this task. Flushing shall be achieved by breaking the vacuum in the system with OFN (Oxygen Free Nitrogen) and continuing to fill until the working pressure is achieved, then venting to the atmosphere, before pulling down to a vacuum. This process shall be repeated until no refrigerant is within the system. When the final OFN charge is used, the system shall be vented down to atmospheric pressure to enable work to take place. This operation is absolutely vital if brazing operations on the pipework are to take place.

Ensure that the outlet for the vacuum pump is not close to any ignition sources and the area is adequately ventilated.

CHARGING PROCEDURES

Formatted: Justified, Indent: Left: 0.5 cm, Hanging: 0.5 cm, Numbered + Level: 1 + Numbering Style: 1, 2, 3, ... + Start at: 1 + Alignment: Left + Aligned at: 1.27 cm + Indent at: 1.27 cm

SAFETY WARNINGS

In addition to conventional charging procedures, the following requirements must be followed.

1. Ensure that contamination of different refrigerants does not occur when using charging equipment. Hoses or lines must be as short as possible to minimise the amount of refrigerant contained within them.
2. Cylinders shall be kept upright.
3. Ensure that the refrigeration system is earthed prior to charging the system with refrigerant.
4. Label the system when charging is complete (if not already).
5. Extreme care must be taken not to overfill the refrigeration system.

Prior to recharging the system, it must be pressure tested with OFN. The system must be leak tested on completion of charging but prior to commissioning. A follow up leak test shall be carried out prior to leaving the site.

DECOMMISSIONING

Before carrying out decommissioning of the unit, it is essential that the technician is completely familiar with the equipment and all its detail. It is recommended good practice that a sample is taken for analysis prior to re-use of reclaimed refrigerant. It is essential that electrical power is available before the task is commenced.

1. Become familiar with the equipment and its operation.
2. Isolate the system electrically.
3. Before attempting the procedure ensure that:
 - a. Mechanical handling equipment is available, if required, for handling refrigerant cylinders;
 - b. All personal protective equipment is available and being used correctly;
 - c. The recovery process is supervised at all times by a competent person;
 - d. The recovery equipment and cylinders conform to the appropriate standards.
4. Pump down the refrigerant system, if possible.
5. If a vacuum is not possible, make a manifold so that refrigerant can be removed from various parts of the system separately.
6. Make sure that the cylinder is situated on the scales before recovery takes place.

7. Start the recovery machine and operate in accordance with manufacturer's instructions.
8. Do not overfill cylinders. (No more than 80 % volume liquid charge).
9. Do not exceed the maximum working pressure of the cylinder, even temporarily.
10. When the cylinders have been filled correctly and the process completed, make sure that the cylinders and the equipment are removed from site promptly and all isolation valves on the equipment are closed off.
11. Recovered refrigerant must not be charged into another refrigeration system unless it has been cleaned and checked.

LABELLING

Equipment must be labelled stating that it has been de-commissioned and emptied of refrigerant. The label shall be dated and signed. Ensure that there are labels on the equipment stating the equipment contains flammable refrigerant.

RECOVERY

When removing refrigerant from a system, either for servicing or decommissioning, all refrigerants must be removed safely. When transferring refrigerant into cylinders, ensure that only appropriate refrigerant recovery cylinders are employed. Ensure that the correct number of cylinders for holding the total system charge are available. All cylinders to be used are designated for the recovered refrigerant and labelled for that refrigerant (i.e. special cylinders for the recovery of refrigerant). Cylinders shall be complete with pressure relief valve and associated shut-off valves in good working order. Empty recovery cylinders are evacuated and, if possible, cooled before recovery occurs.

The recovery equipment shall be in good working order with a full set of instructions concerning the equipment that is at hand and shall be suitable for the recovery of flammable refrigerants. In addition, a set of calibrated weighing scales shall be available and in good working order. Hoses shall be complete with leak-free disconnect couplings and in good condition. Before using the recovery machine, check that it is in satisfactory working order, has been properly maintained and that any associated electrical components are sealed to prevent ignition

Formatted: Justified, Indent: Left: 0.5 cm, Hanging: 0.5 cm, Bulleted + Level: 1 + Aligned at: 1.27 cm + Indent at: 1.27 cm

Formatted: Justified, Indent: Left: 0.5 cm, Hanging: 0.5 cm, Numbered + Level: 1 + Numbering Style: 1, 2, 3, ... + Start at: 1 + Alignment: Left + Aligned at: 1.27 cm + Indent at: 1.27 cm

SAFETY WARNINGS

in the event of a refrigerant release. Consult the manufacturer if in doubt.

The recovered refrigerant shall be returned to the refrigerant supplier in the correct recovery cylinder, and the relevant Waste Transfer Note arranged. Do not mix refrigerants in recovery units and especially not in cylinders.

If compressors or compressor oils are to be removed, ensure that they have been evacuated to an acceptable level to make certain that flammable refrigerant does not remain within the lubricant. The evacuation process shall be carried out prior to returning the compressor to the suppliers. Only electric heating to the compressor body can be employed to accelerate this process. When oil is drained from a system, it must be carried out safely.

COMPETENCE OF SERVICE PERSONNEL

General

Special training is required when equipment with flammable refrigerants is affected. In many countries, this training is carried out by national training organisations that are accredited to teach the relevant national competency standards that may be set in legislation. The achieved competence should be documented by a certificate.

Training

The training should include the substance of the following:

1. Information about the explosion potential of flammable refrigerants to show that flammables may be dangerous when handled without care.
2. Information about potential ignition sources, especially those that are not obvious, such as lighters, light switches, vacuum cleaners, electric heaters.
3. Information about the different safety concepts:
4. Unventilated –Safety of the appliance does not depend on ventilation of the housing. Switching off the appliance or opening of the housing has no significant effect on the safety of the unit. Nevertheless, it is possible that leaking refrigerant may accumulate inside the enclosure and flammable gasses will be released when the enclosure is opened.

5. Ventilated enclosure –Safety of the appliance depends on ventilation of the housing. Switching off the appliance or opening of the enclosure has a significant effect on the safety of the unit. Care should be taken to ensure a sufficient ventilation before opening the unit.
6. Ventilated room – Safety of the appliance depends on the ventilation of the room. Switching off the appliance or opening of the housing has no significant effect on the safety. The room must remain ventilated during the repair procedures.

Information about the concept of sealed components and sealed enclosures according to IEC 60079-15:2010.

INFORMATION ABOUT THE CORRECT WORKING PROCEDURES:

1. Commissioning

- a. Ensure that the floor area is sufficient for the refrigerant charge or that the ventilation duct is assembled in a correct manner.
- b. Connect the pipes and carry out a leak test before charging with refrigerant.
- c. Check safety equipment before putting into service.

2. Maintenance

- ~~1~~-a. Portable equipment shall be repaired outside or in a workshop specially equipped for servicing units with flammable refrigerants.
- ~~2~~-b. Ensure there is sufficient ventilation where the maintenance is carried out.
- ~~3~~-c. Be aware that a malfunction of the equipment may be caused by refrigerant loss and that a refrigerant leak is possible.
- ~~a~~-d. Discharge capacitors in a way that will not cause a spark. The standard procedure of short circuiting the capacitor terminals usually creates sparks.
- ~~b~~-e. Reassemble sealed enclosures accurately. If the seals are worn, replace them.
- ~~e~~-f. Check safety equipment before putting into service.

3. Repair

- ~~1~~-a. Portable equipment shall be repaired outside or in a workshop specially equipped

Formatted: Justified, Indent: Left: 0.5 cm, Hanging: 0.5 cm, Numbered + Level: 1 + Numbering Style: a, b, c, ... + Start at: 1 + Alignment: Left + Aligned at: 2.54 cm + Indent at: 2.54 cm

Formatted: Justified, Indent: Left: 0.5 cm, Hanging: 0.5 cm, Numbered + Level: 1 + Numbering Style: 1, 2, 3, ... + Start at: 1 + Alignment: Left + Aligned at: 1.27 cm + Indent at: 1.27 cm

Formatted: Justified, Indent: Left: 0.5 cm, Hanging: 0.5 cm, Numbered + Level: 1 + Numbering Style: a, b, c, ... + Start at: 1 + Alignment: Left + Aligned at: 2.54 cm + Indent at: 2.54 cm

SAFETY WARNINGS

for servicing units with flammable refrigerants.

2-b. Ensure there is sufficient ventilation where the repair is carried out.

3-c. Be aware that a malfunction of the equipment may be caused by refrigerant loss and that a refrigerant leak is possible.

4-d. Discharge capacitors in a way that won't cause a spark.

5-e. When brazing is required, the following procedures shall be carried out in the right order:

- i. Remove the refrigerant. If the recovery is not required by national regulations, drain the refrigerant to the outside. Take care that the drained refrigerant will not cause any danger. If in doubt, one person should guard the outlet. Take special care that drained refrigerant will not float back into the building.
- ii. Evacuate the refrigerant circuit. Purge the refrigerant circuit with nitrogen for 5 minutes.
- iii. Evacuate again.
- iv. Remove parts to be replaced by cutting, not using a flame.
- v. Purge the braze point with nitrogen during the brazing procedure.
- vi. Carry out a leak test before charging with refrigerant.
- vii. Reassemble sealed enclosures accurately. If seals are worn, replace them.
- viii. Check safety equipment before putting into service.

4. Decommissioning

1-a. If the safety is affected when the equipment is taken out of service, the refrigerant charge must be removed before decommissioning.

2-b. Ensure that there is sufficient ventilation around the equipment's location.

3-c. Be aware that malfunction of the equipment may be caused by refrigerant loss and that a refrigerant leak is possible.

4-d. Discharge capacitors in a way that won't cause a spark.

5-e. Remove the refrigerant. If the recovery is not required by national regulations, drain the refrigerant to outside. Take care that the

drained refrigerant will not cause any danger. If in doubt, one person should guard the outlet. Take special care that drained refrigerant will not re-enter the building.

6-f. Evacuate the refrigerant circuit.

7-g. Purge the refrigerant circuit with nitrogen for 5 min.

8-h. Evacuate again.

9-i. Fill with nitrogen up to atmospheric pressure.

10-j. Put a label on the equipment that the refrigerant is removed.

5. Disposal

1-a. Ensure sufficient ventilation within the working area.

2-b. Remove the refrigerant. If the recovery is not required by national regulations, drain the refrigerant outside. Take care that the drained refrigerant will not cause any danger. If in doubt, one person should guard the outlet. Take special care that drained refrigerant will not re-enter the building.

3-c. Evacuate the refrigerant circuit.

a-d. Purge the refrigerant circuit with nitrogen for 5 min.

b-e. Evacuate again.

e-f. Cut out the compressor and drain the oil.

TRANSPORTATION, MARKING AND STORAGE FOR UNITS THAT EMPLOY FLAMMABLE REFRIGERANTS

Transport of equipment containing flammable refrigerants

Attention is drawn to the fact that additional transportation regulations may exist with respect to equipment containing flammable gas. The maximum number of units or the configuration of the equipment, permitted to be transported together will be determined by the applicable transport regulations.

Marking of equipment using signs

Signs for similar appliances used in a work area generally are addressed by local regulations and give the minimum requirements for the provision of safety and/or health signs for a work location.

All required signs are to be maintained and employers should ensure that employees receive suitable and sufficient instruction and training on

Formatted: Justified, Indent: Left: 0.5 cm, Hanging: 0.5 cm, Numbered + Level: 1 + Numbering Style: a, b, c, ... + Start at: 1 + Alignment: Left + Aligned at: 2.54 cm + Indent at: 2.54 cm

Formatted: Justified, Indent: Left: 0.5 cm, Hanging: 0.5 cm, Numbered + Level: 1 + Numbering Style: a, b, c, ... + Start at: 1 + Alignment: Left + Aligned at: 2.54 cm + Indent at: 2.54 cm

SAFETY WARNINGS

the meaning of appropriate safety signs and the actions that need to be taken in connection with these signs. The effectiveness of signs should not be diminished by too many signs being placed close together.

Any pictograms used should be as simple as possible and contain only essential details.

DISPOSAL OF EQUIPMENT USING FLAMMABLE REFRIGERANTS See national regulations.

Storage of equipment/appliances

The storage of equipment should be in accordance with the manufacturer's instructions.

Storage of packed (unsold) equipment

Storage package protection should be constructed such that mechanical damage to the equipment inside the package will not cause a leak of the refrigerant charge. The maximum number of pieces of equipment permitted to be stored together will be determined by local regulations.

SYSTEM DIAGRAM

INDOOR UNIT

- 1 Air Outlet
- 2 Refrigerant pipes
- 3 Uplift Pump (Integrated)
- 4 Drainage Pipe
- 5 Air Return
- 6 Filter
- 7 Remote Control
- 8 Louvre for airflow
- 9 Refrigerant pipes
- 10 Interconnecting Cable
- 11 Wall Controller (Optional)

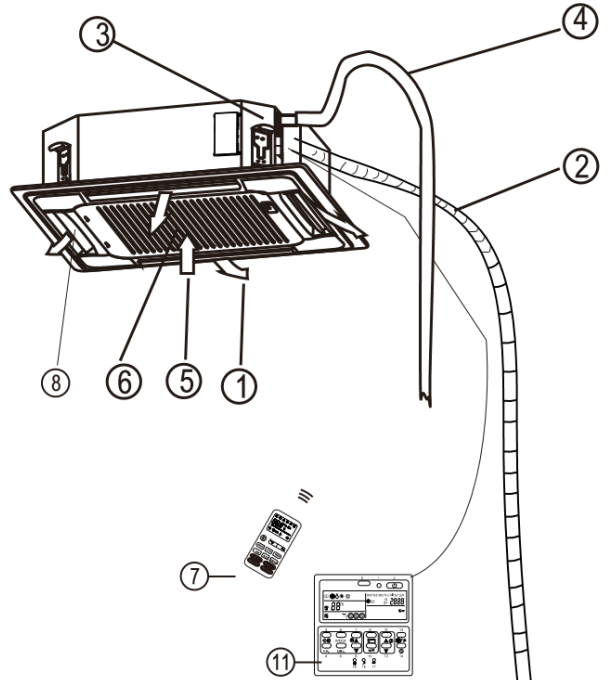

OUTDOOR UNIT

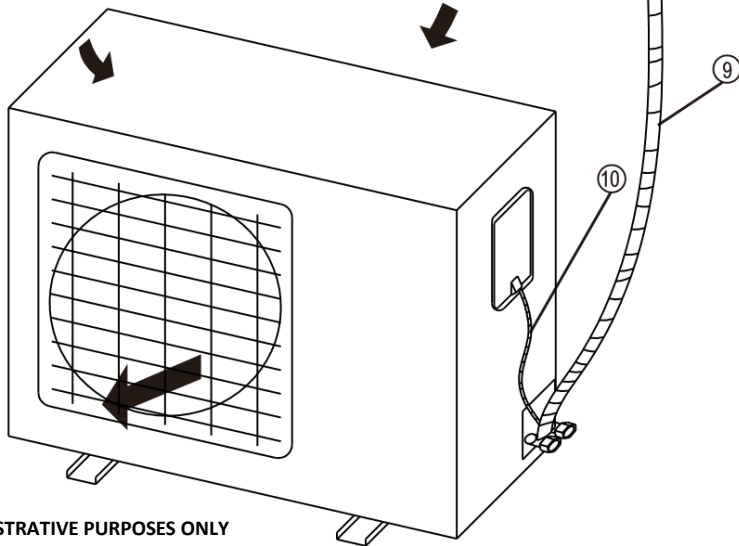

**NOTE: DIAGRAMS FOR ILLUSTRATIVE PURPOSES ONLY
THERE IS A SET OF VALVES FOR EACH INDOOR UNIT**

SYSTEM DIAGRAM

CASSETTE UNIT

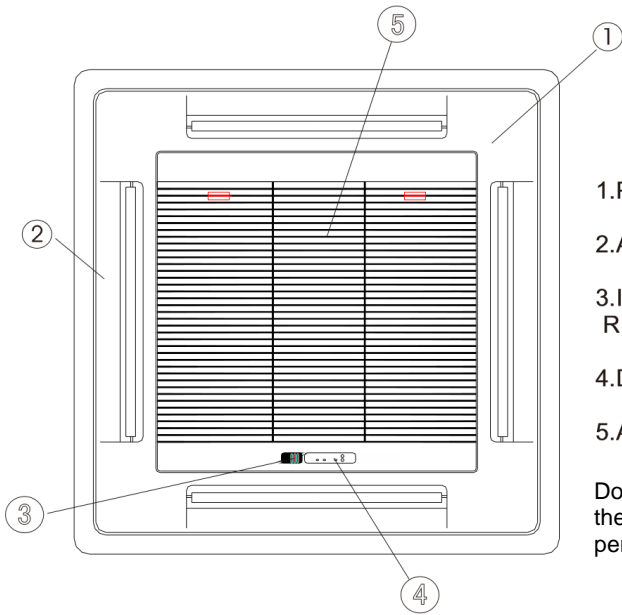

- 1.PANEL
- 2.AIR FLOW LOUVER
- 3.INFRARED SIGNAL RECEIVER
- 4.DISPLAY PANEL
- 5.AIR-IN GRILLE

Do not block the air inlets / outlets on the cassette, as this will reduce performance and may lead to damage.

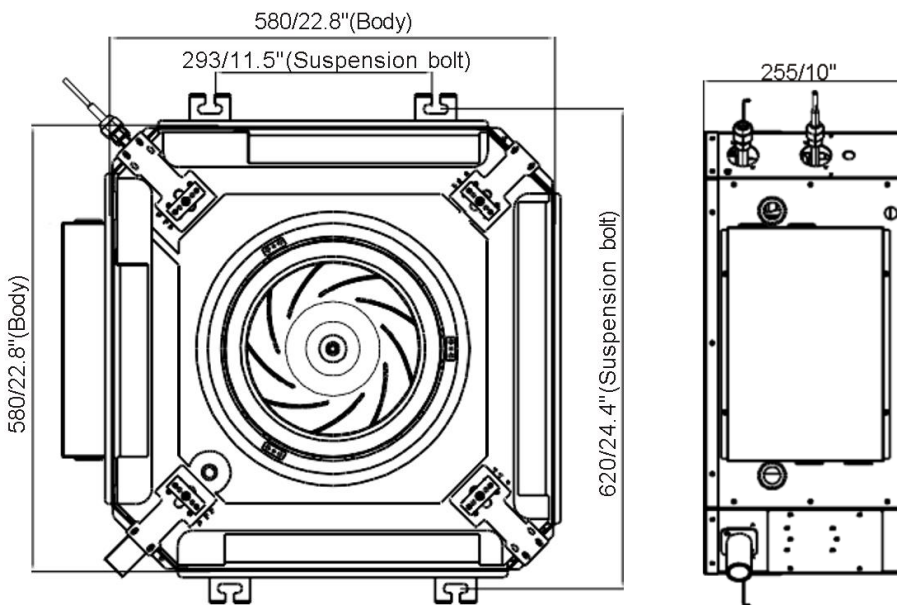

PARTS SUPPLIED

OUTDOOR UNIT:

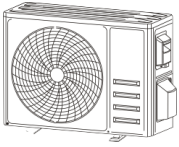

Outdoor Unit x 1



Installation Manual x 1



User Manual x 1



Drain Connector x 1



Rubber Feet Pads x 4



Drainage pipe x 1

WITH EACH CASSETTE INDOOR UNIT:

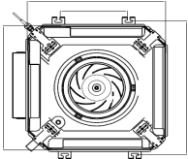

Cassette Unit x 1



Remote Control x 1



PVC Wrap x 1

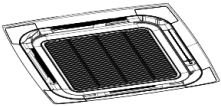

Panel x 1
(Packaged Separately)



Bolts x 4
(Packaged with Panel)



5m Pipe kit x 1
(Packaged Separately)



5.5m Interconnecting Cable x 1
(Packaged with Pipe Kit)

SELECTING THE INSTALLATION LOCATION

INDOOR UNITS

The air inlet and outlet vent should be away from any obstruction, ensuring that there is a good airflow through the whole air-conditioned space. Select a position where the condensing water can be easily drained out, and the indoor unit can be easily connected to outdoor unit. The ceiling where the unit is fixed should be strong enough to withstand the full weight and vibration of the unit. The unit should be accessible for service and maintenance. The height of the installed unit should be more than 200cm from the floor. The air conditioner must not be installed in a wet environment such as a bathroom, shower or swimming pool etc.

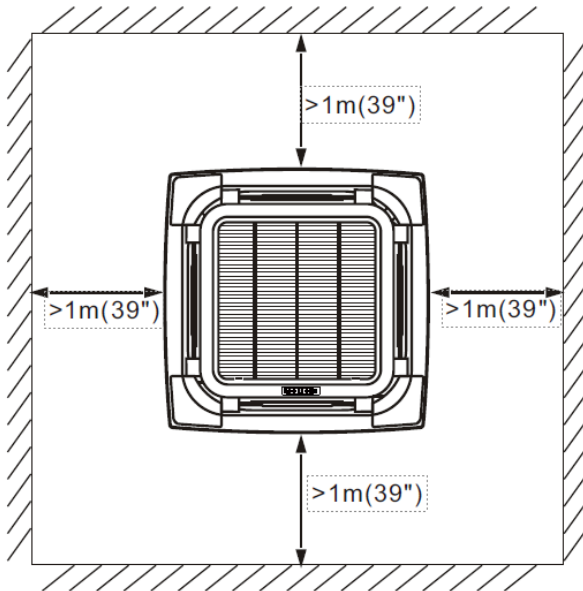

MAIN POINTS TO CONSIDER:

- **DISTANCE TO THE OUTDOOR UNIT** – The unit is supplied with a 5 metre pipe kit for each indoor unit. If a longer pipe run is required, additional refrigerant will need to be added in addition to the purchase of longer pipes.
- **STRENGTH OF THE CEILING** – It must be strong enough to support the weight of the indoor unit, and the vibrations.
- **NOT SUITABLE FOR WET ENVIRONMENTS** – The indoor unit must not be installed in a wet environment such as a bathroom, shower or swimming pool etc.
- **AVOID DIRECT SUNLIGHT** – Keep the indoor unit out of direct sunlight, as this can affect the operation, leading to malfunction.
- **INSTALL AWAY FROM TV AERIALS** – It is advisable that the indoor units are situated at least 3m away from aerials and similar receiving equipment, as in low signal areas this could affect your reception.

SELECTING THE INSTALLATION LOCATION

OUTDOOR UNIT

The outdoor unit should be located in a convenient position, sheltered and well ventilated, outside of direct sunlight or strong winds, which is not on a flood line and where noise and airflow does not cause interference or inconvenience.

Select a location where there are no obstructions to the inlet and outlet vents. The location should be able to withstand the full weight and vibration of the outdoor unit and permit safe installation, while allowing easy access for future maintenance.

Make sure that the outdoor unit is installed following the minimum spacing on the diagram below:

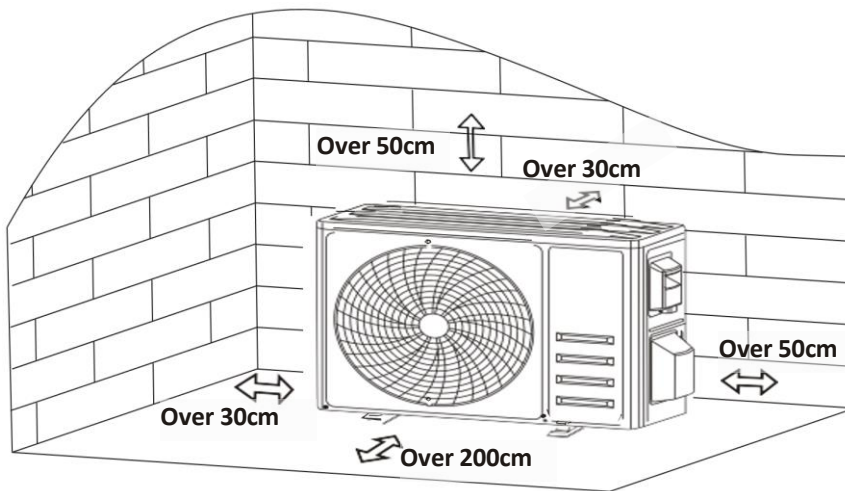

If the outdoor unit is to be installed at ground level in a location which is accessible to the public and/or children, it may be advisable that steps are taken to protect the unit from tampering, and objects from being inserted into the openings.

The outdoor unit can also be installed on a suitable wall bracket, as long as the above ventilation requirements are followed. Care should be taken to ensure both the wall and bracket are strong enough to support the full weight of the unit. If installing on a wall bracket, drainage of the outdoor unit should also be considered. We also advise that antivibration pads / fixings (not supplied) are used on the feet to prevent the amplification of running noises.

TECHNICAL INFORMATION FOR INSTALLATION

PIPE LENGTH AND ADDITIONAL REFRIGERANT

The air conditioner is supplied with a 5 ½ meter pipe kit, but will support pipe runs upto the length specified below. When installing longer pipe runs, refrigerant should be added following the table below:

Length of pipe with standard charge	5 m
Maximum distance between indoor and outdoor unit	15m
Additional refrigerant charge	15g/m
Max. diff. in level between indoor and outdoor unit	10m
Type of refrigerant	R32

TORQUE PARAMETERS

All pipework for the air conditioner should be tightened, following the table below:

PIPE SIZE	FORCE (Nm)
1 /4 (6.35mm)	15 - 20
3/8 (9.52mm)	31 - 35
1/2 (12mm)	45 - 50
5/8 (15.88mm)	60 - 65

CROSS SECTIONAL AREA OF CABLES

Power should be provided to the outdoor unit using a 3-core cable with a minimum CSA of 1.5mm². Each indoor unit is provided with power from the outdoor unit, and so requires a 5-core cable to carry the signal, earth and power, these cables should have a minimum CSA of 1.0mm².

THE MAXIMUM CHARGE AND THE REQUIRED MINIMUM FLOOR AREA

The minimum room size suitable for the appliance is given in the safety warnings based on the charge supplied within the outdoor unit. If longer pipe runs are used, the information below should be used to understand if the room is suitable for installation, or whether extra measures should be taken.

	Formula	Result for R32 (LFL - 0.038 kg/ m ³)
M ₁	= (4 m ³) x LFL	0.152
M ₂	= (26 m ³) x LFL	0.988
M ₃	= (130 m ³) x LFL	4.94
LFL is the lower flammable limit in kg/ m ³		

For the appliances with a charge amount m1 < M = m2:













The maximum charge in a room shall be in accordance with the following:

$$M = 2.5 \times (\text{LFL})^{(5/4)} \times h_0 \times (A)^{1/2}$$

The required minimum floor area Amin to install an appliance with refrigerant charge M (kg) shall be in accordance with following:

$$A = (M / (2.5 \times (\text{LFL})^{(5/4)} \times h_0)) ^2$$

TOOLS RECOMMENDED FOR INSTALLATION

TOOL	PICTURE	TOOL	PICTURE	TOOL	PICTURE
Standard Wrench		Pipe Cutter		2 Inch Pipe Clips	
Adjustable/ Crescent Wrench		Screwdrivers (Phillips & Flat)		Cable Ties	
Torque Wrench		Manifold and Gauges		Expanding foam	
Hex Keys / Allen Keys		Spirit Level		Silicone Sealant	
Drill & Masonry Drill Bits		Flaring Tool		Pencil and Chalk	
Core Hole Cutter		Clamp on Multimeter		Dust Sheets	
Vacuum Pump		Refrigerant Scale		Stepladder	
Safety Glasses and Mask		Micron Gauge		Pipe and Cable Detector	
Work Gloves		Tape Measure		Circuit Breaker	
Leak Detector (R32)		Note: This table is for guidance only, and the tools required will vary depending on the installation location / requirements.			

INSTALLATION

Before starting installation, it is advisable to read through all the installation steps, to give a good understanding of the process. Installation must be conducted by an F-Gas certified engineer.

INDOOR UNIT INSTALLATION

Where possible the following areas should be avoided to avoid potential problems with the appliance and/or safety risks:

1. Where flammable gas is likely to be in the air.
2. Where the air has a high salt content
3. Where caustic gasses are likely to be in the air.
4. Which is unable to safely bear the weight of the unit
5. With high levels of electromagnetic interference.
6. Where the unit may be subjected to acid or alkaline solutions.
7. With high levels of humidity.

Select the installation location taking consideration of the following:

1. Route of the pipework / wiring
2. Access to the upper parts of the unit for connection of the pipework/wiring after hanging the unit
3. Ability of the area to support the weight of the unit.

Before hanging the unit the refrigerant pipes, drain pipe and connection wires should be led to the location of the outdoor unit. Confirm the size of the indoor unit and ceiling opening using the supplied installation template.

INSTALLATION

1. PREPARATION WORK ON THE CEILING

The indoor cassette unit is designed to be supported by 4 x threaded rods, connecting it to a solid structure above.

The unit must be installed in accordance with current building regulations and the Installation method should be adjusted depending on the structure of the ceiling. If in any doubt about what installation method is suitable, independent advice should be sought.

After opening a hole, ensure that the ceiling is horizontal and strong to prevent vibration during operation. Reinforcement of the ceiling around the opening may be necessary.

If beams require cutting to accommodate the unit, the remaining beams around the area should be reinforced to compensate for the extra weight they are now supporting.

WOODEN CONSTRUCTION

Fix a square length of timber over the roof beam and install the hanging screw bolts into it.

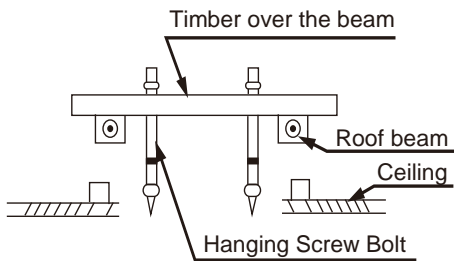

NEW CONCRETE PANELS

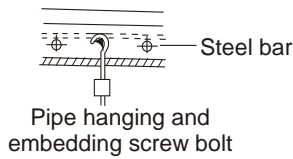

FINISHED CONCRETE PANELS

Install the hanging hook using expandable bolts into the concrete to a depth of at least 45mm to prevent them coming loose during operation.

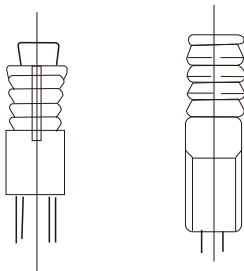

STEEL ROOF BEAM STRUCTURE

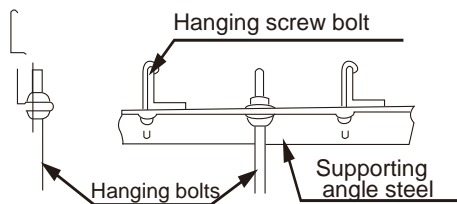

INSTALLATION

2. HANGING THE CASSETTE UNIT

Adjust the under side of the gasket so it sits 90mm above the ceiling.

Overhang the cassette unit above the ceiling, slotting the bars into the brackets on the cassette unit and tightening into position, ensuring that the unit is level.

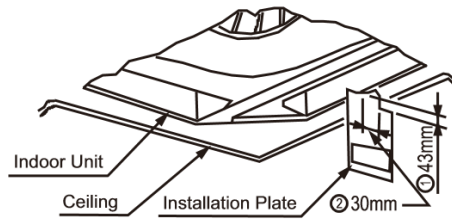
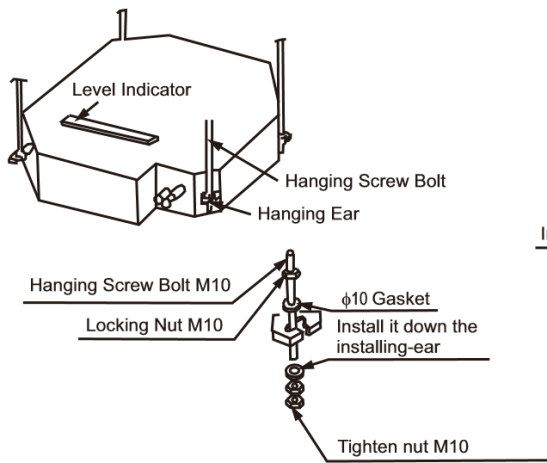
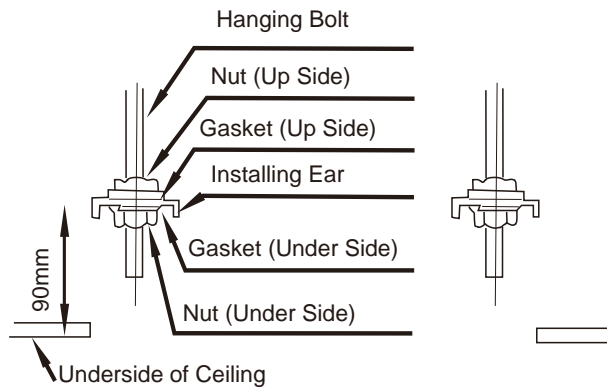

INSTALLATION

3. DRAIN PIPE INSTALLATION

- Ensure that the drainage pipe used has sufficient insulation to prevent condensation forming on the pipework.
- As the drain is gravity fed, it must decline at a slight angle (2/100) with no twisting or bending to aid drainage.
- The maximum length of the drain pipe must not exceed 20m, and must be suitably supported to prevent bumps and bends.
- Ensure that pressure is not placed on the pipe, as this may restrict the flow of condensate from the unit.
- The flexible hose must be mounted horizontally.

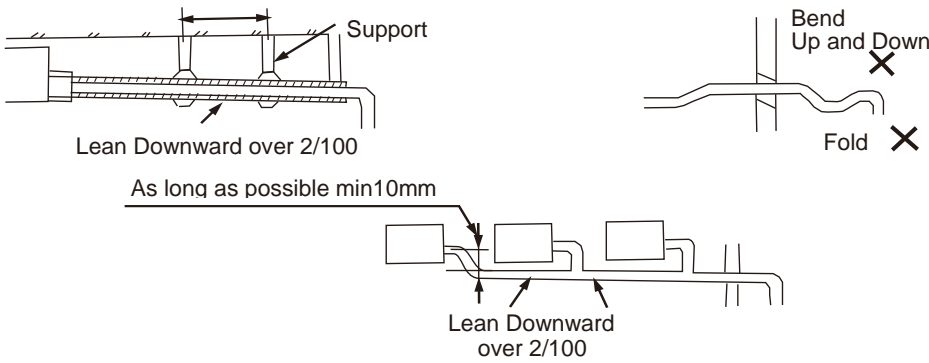

We advise on the following materials to be used:

Drain Pipe	Polyvinyl chloride pipe (32mm outer diameter)
Heat Insulation	Foamed polyethylene insulation plate (10mm thickness)

- Use polyvinyl chloride glue at any connection points to prevent water leakage
- Place glue over the front 40mm of the pipe before inserting it into the transparent pipe.
- Allow 10 minutes for the glue to dry before placing any pressure on it.

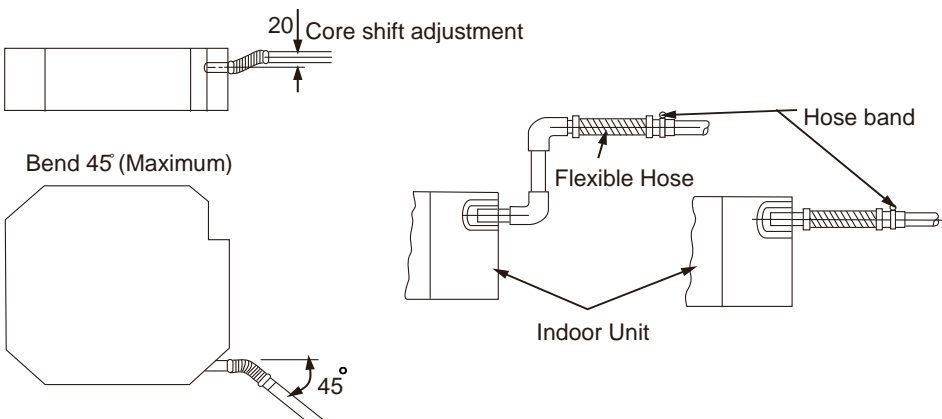

INSTALLATION

DRAINAGE UPWARDS

Upon leaving the unit the drainage pipe can have an initial horizontal lift of upto 360mm, before starting the downwards inclination indicated on the previous page. This must be within 100mm of the drainage pipe leaving the cassette unit.

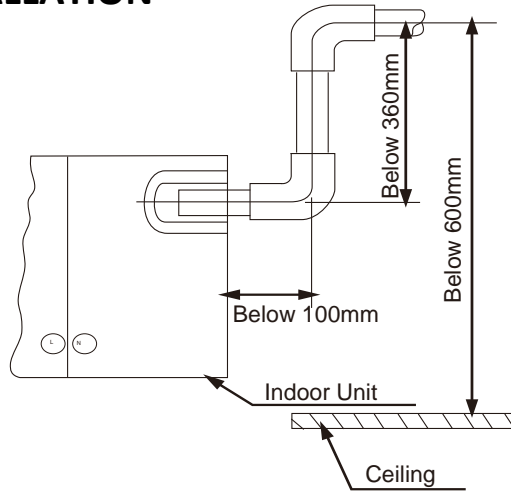

4. DRAINAGE TEST

Once the drain pipe has been fully installed, the pipework should be initially be visually checked. Once visually checked, an operation test can be conducted.

1. Ensure power is not connected to the unit.
2. Remove the water tank cover and insert 600ml of water, ensuring that it does not touch the drain pump motor.
3. Disconnect the water level switch.
4. Connect the power to the unit, and the drain pump should start immediately.
5. Allow to run for 1 minute.
6. Following the test, disconnect the power and reconnect the water level switch.

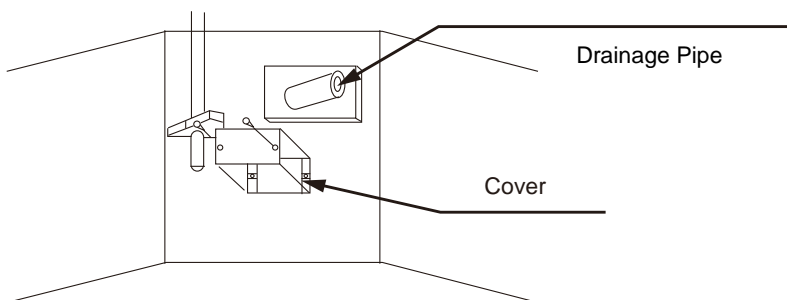

INSTALLATION

5. PANEL INSTALLATION

The panel should be installed after the pipework and wiring have been connected.

Following installation ensure that the gaps between the panel and the ceiling are sealed to prevent air and liquid leakage.

1. Push the two grill switched towards the centre to unhook the grill before pulling the centre of the panel downwards to remove it from the panel.
2. Hold the grill at a 45° angle to the unit and lift to unhook from the rear of the panel.

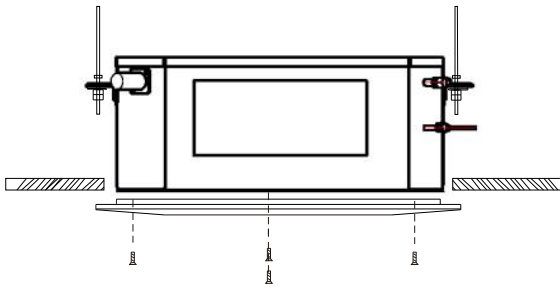
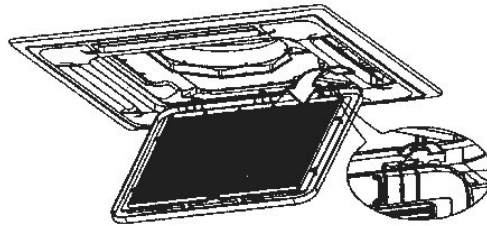

3. Hold the panel against the cassette unit, lining up the red arrow on the electrical box with the one on the panel, before loosely fastening with the M6 bolts.
4. Connect the cables for the step motors and display panel to the cassette following the wiring diagram provided, ensuring that the cables will not get trapped when tightening the panel.

5. If the optional wired display panel is also to be installed, it should also be connected to the connector on the cassette unit – see the wiring diagrams.
6. Check the position of the panel before fully tightening the bolts, so that the panel is flush to the cassette unit.
7. Reattach the grill to the panel following the reverse of removal.
8. If there is a gap between the panel and the ceiling after tightening the screws, readjust the height of the cassette, ensuring it is kept level.

6. REPEAT FOR EACH INDOOR UNIT

Steps 1 – 8 should now be repeated for each of the indoor units in the system.

INSTALLATION

OUTDOOR UNIT INSTALLATION

The outdoor unit must be installed in a horizontal position, and secured into place. There should be no movement of the outdoor possible once installed, to prevent the risk of damage to the pipework following installation. We would advise moving the unit to its final position in the original packaging to prevent the risk of damage.

1. INSTALL THE DRAINAGE HOSE

- Install the drain connector on the underside of the outdoor unit,
- Connect the drainage hose to the drain connector.
- Ensure the joint is firm, and it is well sealed.
- Wrap the joint with waterproof tape, to ensure that it will not leak following installation

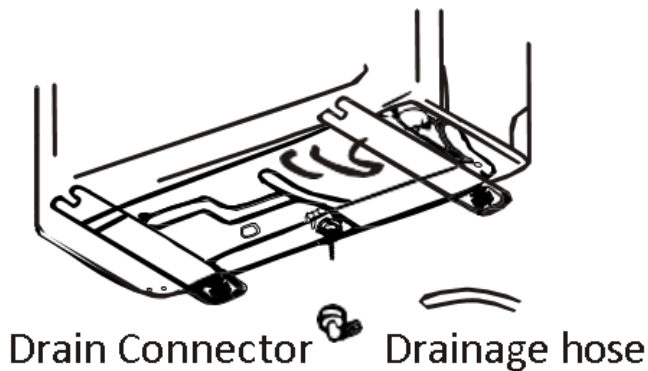

2. SECURE THE OUTDOOR UNIT IN POSITION

The outdoor unit can either be floor mounted or attached to a wall using a suitable wall bracket.

FLOOR MOUNTED:

- Place the outdoor unit in position and park the holes in the feet using a piece of chalk or similar.
- Drill the holes and clean any dust created before inserting suitable plugs.
- Place the outdoor unit in position over the holes.
- Install the 4 rubber feet pads on the underside of the feet, as this will help to reduce vibrations and noise.
- Fix the outdoor unit into position using suitable anchor bolts.

WALL MOUNTED:

Follow the instructions provided with the wall mounting bracket. It is the installers responsibility to ensure that the bracket is suitable to safely support the weight of the outdoor unit, understanding the extra strain on the bracket from the vibration of the unit.

It is also advisable to install extra dampening between the unit, bracket and wall to help prevent the amplification of operating noise from the unit.

INSTALLATION

3. CONNECTING THE REFRIGERANT PIPES FOR THE FIRST INDOOR

- Unscrew the valve cover from the front of the valves.
- Remove the plastic protective caps from the end of valves.

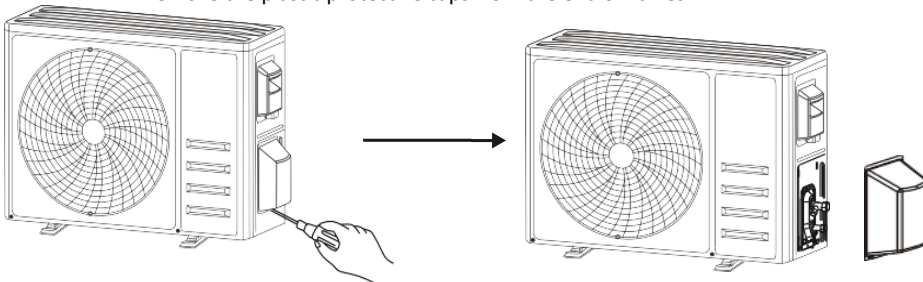

- Check the end of the pipework to ensure that it is clean and free from dirt.
- Remove the plastic cover in the pipe ports and ensure the port is clean.
- After aligning the pipe with the valve, rotate the flare nut to tighten by hand.
- Use a torque wrench to tighten the flare nut following the table in the TECHNICAL INFORMATION FOR INSTALLATION section.

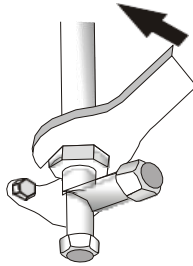
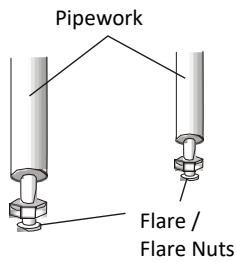

4. CONNECTING THE CABLES FOR THE FIRST INDOOR

- Use a Philips screwdriver to unscrew the cover from the terminals, grasp and press it down gently to remove it from the unit.
- There is a wiring diagram on the rear of the cover which should be referred to when connecting the units.

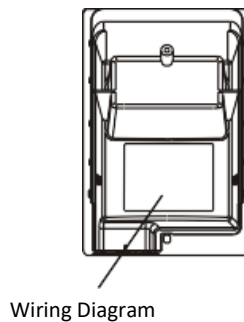
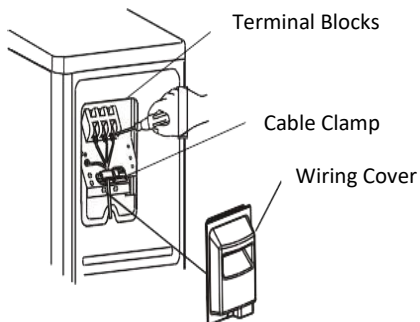

- Unscrew the cable clamp and remove it from the unit

INSTALLATION

- According to the wiring diagram pasted inside the wiring cover, connect the connecting wires to the corresponding terminals (also matching the port that the pipework for that unit is connected)

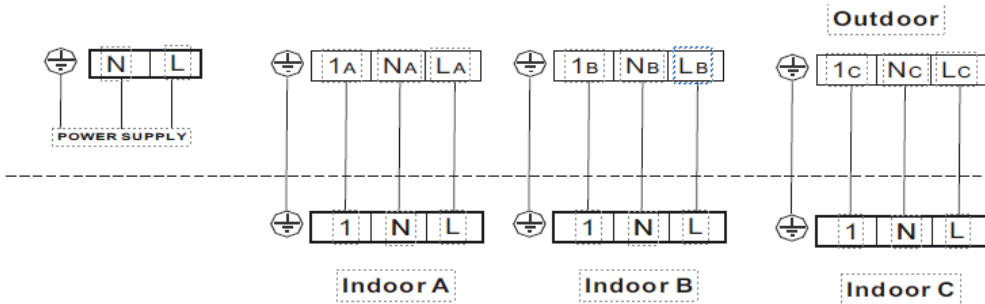

- Ensure all connections are firmly and securely fastened.

5. REPEAT FOR EACH INDOOR UNIT

Steps 3 – 4 should now be repeated to connect each indoor to the outdoor unit.

6. CONNECT THE MAINS POWER CABLE TO THE UNIT

- The appliance should be installed in accordance with national wiring regulations.
- Ensure that the circuit is disconnected from the mains, before connecting.
- If the supply cord is damaged, it must be replaced by the manufacturer, its service agent or a suitably qualified person in order to avoid a hazard.
- The unit is designed to be hard wired and a suitable switch with a contact separation of at least 3mm in all poles must be added to the fixed wiring.
- The air conditioner electrical wiring must follow the specific country regulations.
- Once the wiring is connected, reinstall the cable clamp and wiring cover.
- Do not power the circuit at this point.

7. FINALISE FIXING OF THE PIPEWORK

As the pipework and cables are now all connected, the pipework can now be fully fixed into its final position.

INSTALLATION

8. VACUUM PUMP THE SYSTEM

This needs to be conducted for each indoor connection:

- Use a spanner to remove the protective caps from the service port on the low pressure and high-pressure valves on the outdoor unit.
- Connect the pressure hose of manifold gauge to the service port on the outdoor unit low pressure valve.
- Connect the charge hose from the manifold gauge to the vacuum pump.
- Open the low-pressure valve on the manifold gauge and close the high-pressure valve.
- Turn on the vacuum pump to vacuum the system.
- The vacuum time should not be less than 15 minutes, or until the compound gauge indicates -0.1 MPa.
- Close the low-pressure valve on the manifold gauge and turn off the vacuum.
- Hold the pressure for 5 minutes, make sure that the rebound of compound gauge pointer does not exceed 0.005 MPa.
- Open the low-pressure valve anti clockwise by 1/4 turn using an Allen key to let a little refrigerant fill in the system, and close the low-pressure valve after 5 seconds and quickly remove the pressure hose.
- Check all joints for leakage with soapy water or a leak detector.
- Fully open the low-pressure valve and high-pressure valve of the outdoor unit with hexagonal wrench.
- Reinstall the protective caps of the service port, low pressure valve and high-pressure valve on the outdoor unit.
- Repeat for each circuit.
- Reinstall the valve cover.

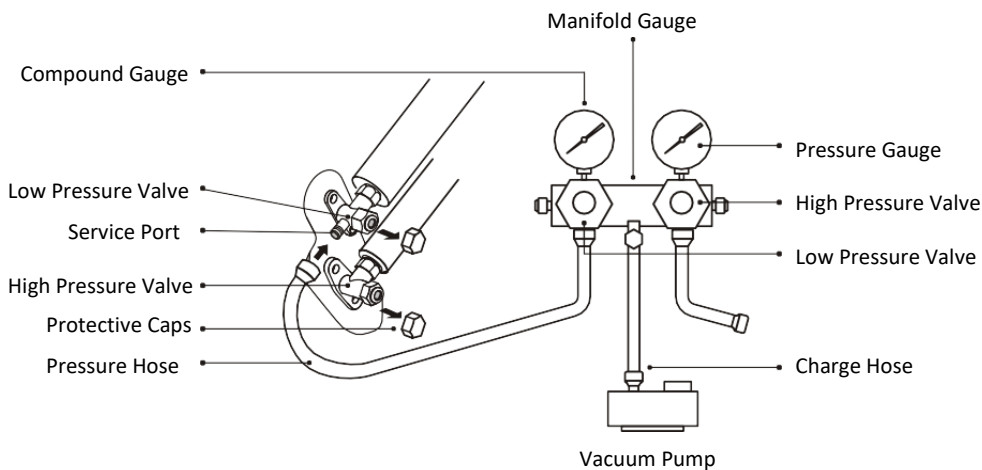

TEST OPERATION

PRE-TEST INSPECTION

DESCRIPTION	INSPECTION METHOD
Electrical safety inspection	<ul style="list-style-type: none"> • Check whether the power supply voltage complies with specification. • Check whether there is any wrong or missing connection between the power lines, signal line and earth wires. • Check whether the earth resistance and insulation resistance comply with requirements.
Installation safety inspection	<ul style="list-style-type: none"> • Confirm the direction and smoothness of drainage pipe. • Confirm that the joint of refrigerant pipe is installed completely. • Confirm the safety of outdoor unit, mounting plate and indoor unit installation. • Confirm that the valves are fully open. • Confirm that there are no foreign objects or tools left inside the unit. • Complete installation of indoor unit air inlet grille and panel.
Refrigerant leakage detection	<ul style="list-style-type: none"> • The piping joint, the connector of the two valves of the outdoor unit, the valve spool, the welding port, etc., where leakage may occur. • Foam detection method: Apply soapy water or foam evenly on the parts where leakage may occur, and observe whether bubbles appear or not, if not, it indicates that the leakage detection result is safe. • Leak detector method: Use a professional leak detector and read the instruction of operation, detect at the position where leakage may occur. • The duration of leak detection for each position should last for 3 minutes or more; If the test result shows that there is leakage, the nut should be tightened and tested again until there is no leakage; After the leak detection is completed, wrap the exposed pipe connector of indoor unit with thermal insulation material and wrap with insulation tape.

TEST OPERATION

TEST RUN

1. Turn on the power supply.
2. Press the ON/OFF button on the remote control to turn on the air conditioner.
3. Press the Mode button to switch the mode COOL and HEAT.
In each mode set as below:
COOL-Set the lowest temperature
HEAT-Set the highest temperature
4. Run for about 8 minutes in each mode and check all functions are properly run and respond the remote control.
Recommended function checks:
That the unit provides both heating and cooling
That the water drains properly from the drainage hose
That the Louvres and flap function properly
5. Repeat for each indoor unit
6. Observe the test run state of the air conditioner at least 30 minutes.
7. After successfully completing the testing, change to the required settings and press ON/OFF button on the remote control to turn off each indoor unit.
8. If the user requires the WiFi functions, these should also be set up following the user manual.
9. Inform the user to read the user manual carefully before use, and demonstrate to the user how to use the air conditioner, the necessary knowledge for service and maintenance, and the reminder for storage of accessories.

ELECTRICAL WIRING DIAGRAMS

Please note: The diagrams provided in the manual are for guidance only. Due to continual product development the diagrams provided on the units themselves should be followed where any discrepancies are found

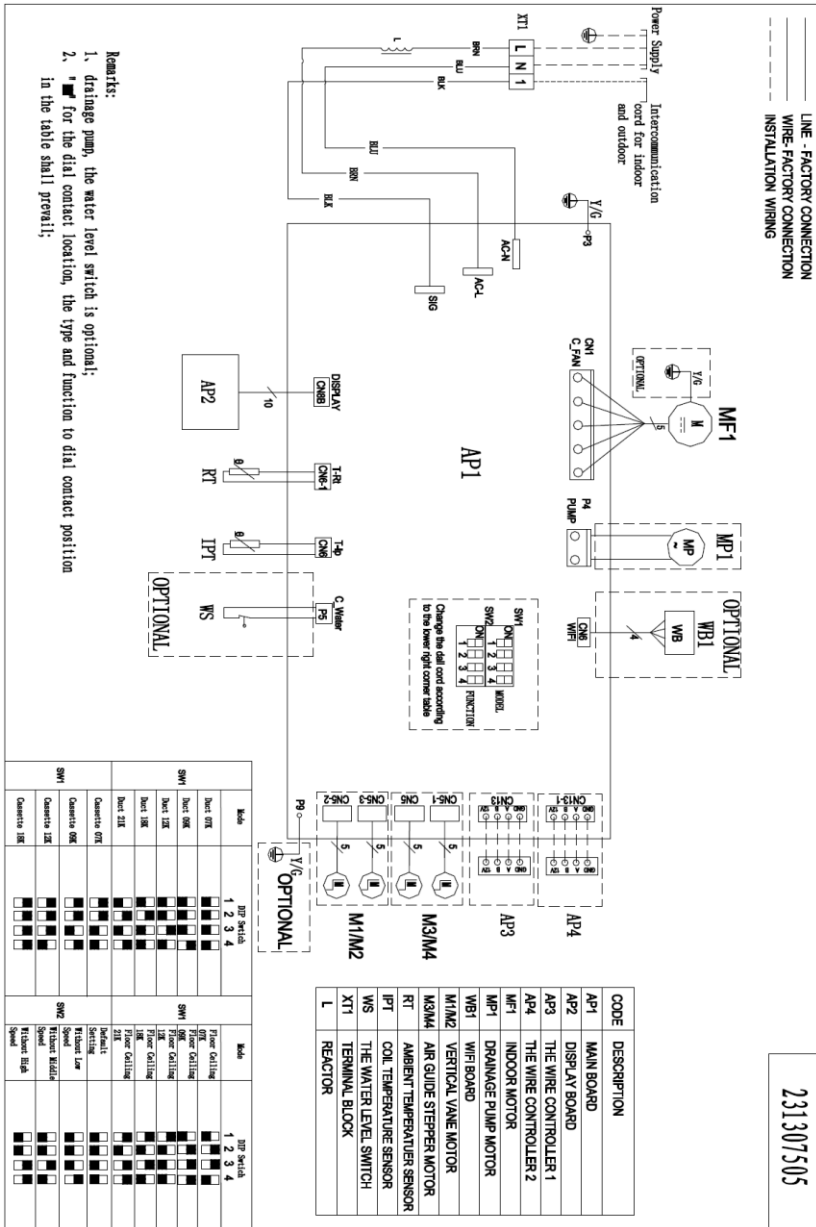

ELECTRICAL WIRING DIAGRAMS

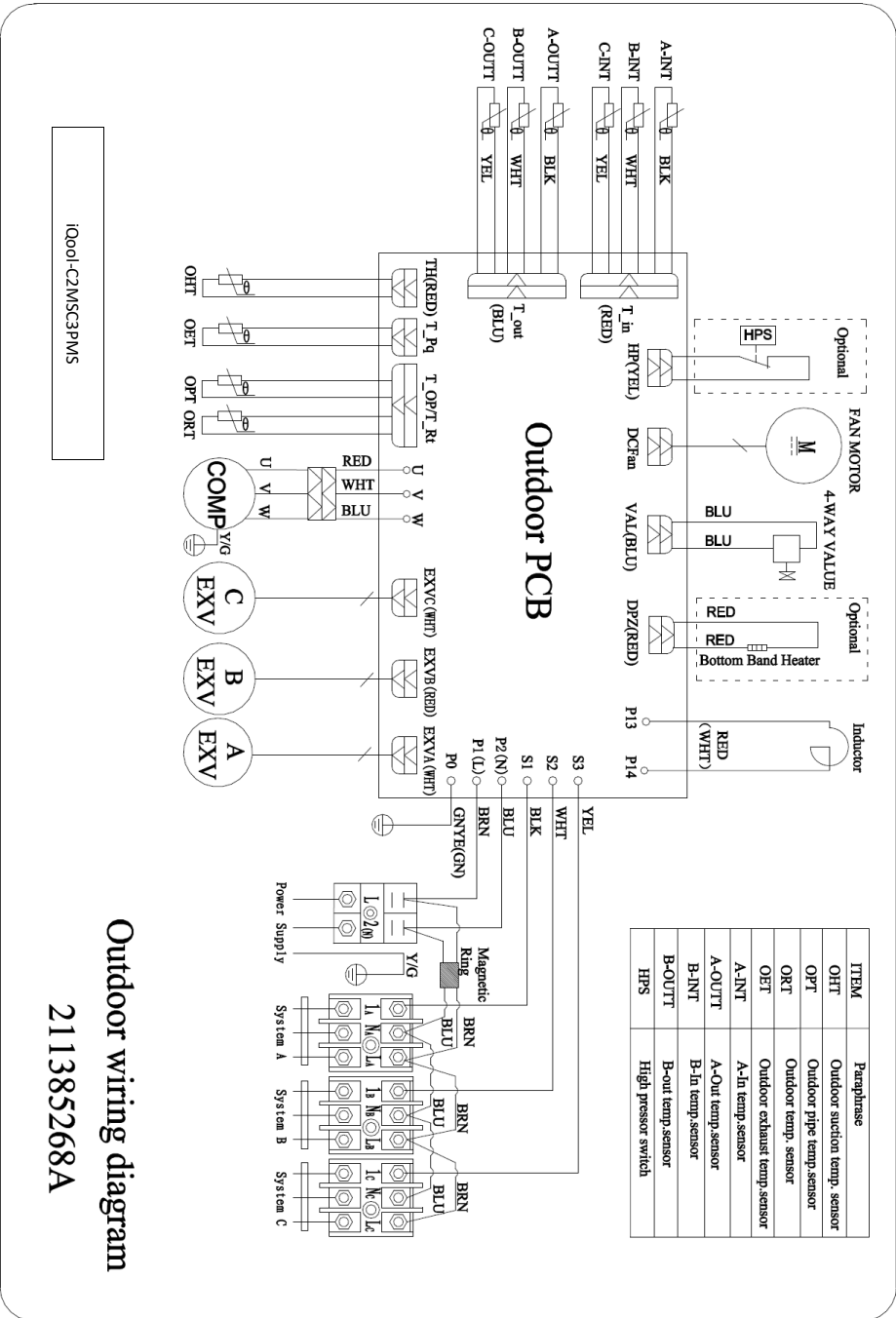

Outdoor wiring diagram

211385268A

IQool-C2M/SC3PMS

ELECTRICAL WIRING DIAGRAMS

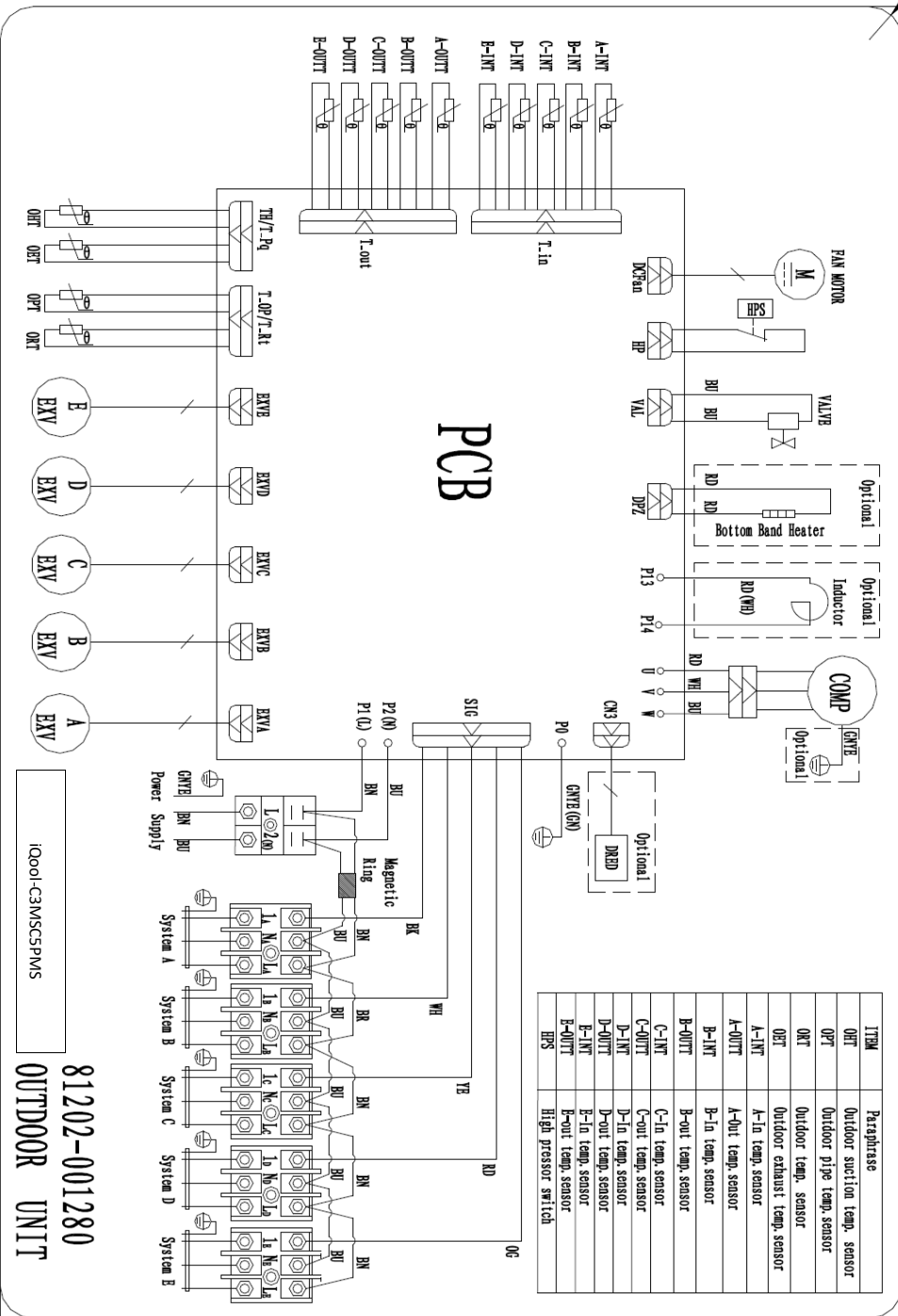

81202-001280
OUTDOOR UNIT

TROUBLESHOOTING AND SELF DIAGNOSIS

MALFUNCTION	POSSIBLE CAUSE
The appliance does not operate	Power failure
	Damaged indoor/outdoor unit fan motor
	Faulty compressor thermomagnetic circuit breaker
	Faulty protective device or fuses
	Loose connections
	Self protection in adverse conditions
	Voltage higher / lower than the voltage range
	Active TIMER-ON function
Damaged electronic control board	
Strange odour	Air filter dirty
Noise of running water	Back flow of liquid in the refrigerant circulation
A fine mist comes from the air outlet	This occurs when the air in the room becomes very cold, for example in the COOLING or DEHUMIDIFYING modes.
A strange noise can be heard	This noise is made by the expansion or contraction of the front panel due to variations in temperature and does not indicate a problem.
Insufficient airflow, either hot or cold	Inappropriate temperature setting.
	Air inlet or outlet of indoor or outdoor unit has been blocked.
	Air filter is blocked.
	Fan speed set at minimum.
	Other sources of heat in the room.
No refrigerant.	
The appliance does not respond to commands	Remote control is not near enough to indoor unit.
	Battery in Remote controller may have been exhausted..
	Obstacles between remote control and signal receiver in indoor unit.
The display is off	DISPLAY button pressed on remote
	Power failure
Remote cannot select heating mode.	Remove the batteries from the remote and follow the guide for setting up the remote.
Switch off the air conditioner immediately and cut off the power supply in the event of:	
Strange noises during operation.	
Faulty electronic control board	
Faulty fuses or switches.	
Spraying water or objects inside the appliance.	
Overheated cables.	
Very strong smells coming from the appliance.	

TROUBLESHOOTING AND SELF DIAGNOSIS

ERROR SIGNALS ON THE DISPLAY	
In case of error, the display on the indoor unit shown the following error codes:	
Error Code	Failure type
E0	Indoor and outdoor communication failure
EC	Outdoor communication failure
E1	Indoor room temperature sensor
E2	Indoor coil temperature sensor
E3	Outdoor coil temperature sensor
E4	System abnormality
E5	Model configuration wrong
E6	Indoor fan motor fault
E7	Outdoor temperature sensor
E8	Exhaust temp. sensor
E9	IPM drive and module fault
EA	Current sensor fault
Ed	Indoor EEPROM fault
EC	Outdoor Communication fault
EE	Outdoor EEPROM fault
EF	Outdoor fan motor fault (DC motor)
EH	Outdoor suction temperature sensor fault
En	Outdoor gas pipe temperature sensor fault
EP	Temp. switch fault (on top of the compressor)
EU	Voltage sensor fault
Ey	Outdoor liquid pipe temperature sensor fault
Protection Display Code List	
PA	Indoor run mode conflict
P1	Overvoltage /lower voltage protection
P2	Overcurrent protection
P4	Exhaust over temperature protection
P5	Too cool protection in cooling mode
P6	Overheat protection in cooling mode
P7	Overheat protection in heating mode
P8	Outdoor over temperature / lower temperature protection
P9	Drive protection (software control)
P0	Module protection (hardware control)

TROUBLESHOOTING AND SELF DIAGNOSIS

OUTDOOR UNIT FAULT CODES

The outdoor unit has an LED on the power board. This LED will be illuminated when the compressor is running and blink 1s on and 1s off when the compressor is in standby. If there is a fault on the outdoor unit, it will blink on and off for half a second at a time, followed by a 3s gap. The number of consecutive blinks will show the fault as per the table below:

No. of blinks	Fault
1	IPM protection
2	Over voltage /lower voltage
3	Overcurrent
4	Exhaust over temperature protection
5	Outdoor coil over temperature protection
6	Drive fault and protection (V1, VP1)
7	Communication fault with indoor unit
8	Compressor overheat fault (compressor top switch)
9	Short-circuit / open-circuit fault of outdoor temperature sensor
10	Short circuit / open-circuit fault of outdoor heat exchanger temperature sensor
11	Short-circuit / open-circuit fault of exhaust temperature sensor
12	Voltage sensor fault
13	Current sensor fault
14	IPM fault
15	Communication fault between power source board and IPM
16	No feedback from DC fan motor(outdoor unit)
17	Defrost state

WIFI CONTROL TROUBLESHOOTING

Description	Possible Cause
Air conditioner can't be configured successfully	<ol style="list-style-type: none"> 1. Check the mobile device is connected to WIFI 2. Check the AC is connected 3. Check that any firewall or other restrictions are causing problems 4. Check the router is functioning normally 5. Check that the router isn't blocking the App
Mobile device can't control the air conditioner	The app displays "Identification failed". This indicates that the AC has been reset and the mobile device has lost contact with the AC. Reconnect the device following the above instructions. If this fails, delete the AC from your devices list and start the install process from the beginning.
Mobile device can't find AC	<p>The app displays "Air conditioner out of line". Check the below:</p> <ol style="list-style-type: none"> 1. The AC has been reconfigured 2. The AC is not receiving power 3. The router is not powered on 4. The AC can't connect to router 5. The AC can't connect to network through the router 6. The mobile device can't connect to the router 7. The mobile device can't connect to a network (when being used remotely)

TECHNICAL SPECIFICATION

Model	iQool-C2MSC3PMS		iQool-C3MSC5PMS	
Rated voltage and frequency (Ph-V-Hz)	220-240V~/50HZ		220-240V~/50HZ	
Fuse Required	20A		40A	
Mode	Cooling	Heating	Cooling	Heating
Rated capacity (W)	7900 (2800~8800)	7960 (2450~8800)	12200 (3300~13100)	12200 (3300~13100)
Power input (W)	2633 (350~2850)	2123 (420~2850)	3812 (730~5400)	3686 (800~5400)
Current input (A)	12.7 (1.6~14.0)	10.9 (1.9-14.0)	16.8 (3.2~24.0)	15.8 (3.5~24.0)
SEER/SCOP(W/W)	6.1 (A++)	4.0 (A+)	6.1 (A++)	4.0 (A+)
Nominal load (kW)	7.9	5.8	12.2	9.5
Balance point temperature heating (°C)	/	-7	/	-7
Min. outdoor operating temperature (°C)	/	-15	/	-15
Thermostat-off mode (W)	51		80	
Standby mode (W)	10		8	
Off mode (W)	0		0	
Annual consumption (kW)	294	1540	700	3325
Copper Pipe Type length	5m		5m	
Liquid side / Gas side (mm/inch)	6.35 (1/4") + 9.52 (3/8")		6.35 (1/4") + 9.52 (3/8")	
Max. refrigerant pipe length for each unit	15m		15m	
Max. elevation	10m		10m	
Interconnecting Cable	5×1.0mm ²		5×1.0mm ²	
12K Indoor	Air Flow (m ³ /h)	600		
	Dimensions (L*W*H) (mm)	Cassette: 574×574×250 / Panel: 660×30×660		
	Packaging (L*W*H) (mm)	Cassette:725×725×330 / Panel: 745×100×745		
	Net / Gross weight (Kg)	Cassette: 20/24 / Panel: 2.5/4.5		
	Noise – Sound pressure level (dB/A)	42		
	Noise – Sound power level (dB/A)	52		
	Moisture Removal (L/h)	1.2		
18K Indoor	Air Flow (m ³ /h)	800		
	Dimensions (L*W*H) (mm)	574×574×250 / Panel: 660×30×660		
	Packaging (L*W*H) (mm)	725×725×330 / Panel: 745×100×745		
	Net / Gross weight (Kg)	Cassette: 20/24 / Panel: 2.5/4.5		
	Noise – Sound pressure level (dB/A)	46		
	Noise – Sound power level (dB/A)	56		
	Moisture Removal (L/h)	1.5		
Outdoor	Dimension (L*W*H) (mm)	968×655×375	990×910×340	
	Packaging (L*W*H) (mm)	1015×715×425	1030×950×430	
	Net / Gross Weight (Kg)	46 / 51	73 / 85	
	Noise – Sound pressure level (dB/A)	58	60	
	Noise – Sound power level (dB/A)	68	70	
	Refrigerant type/weight	R32 / 1600g	R32/3000g	
	CO2 equivalent (T)	1.08	2.025	
	Defrost mode	Automatic defrosting	Automatic defrosting	
Applicable climate types	Cooling (15°C – 53°C) / Heating (-20°C – 30°C)			

Due to continuous product development process specification may change

SUPPORT

electriQ UK SUPPORT

Please, for your own convenience, check the troubleshooting guide before calling the service line.

Support@electriQ.co.uk

0330 390 3061

Office hours: 9AM - 5PM Monday to Friday

www.electriQ.co.uk

Unit 2A, Trident Business Park,
Neptune Way, Leeds Road, Huddersfield, HD2 1UA

EU DECLARATION OF CONFORMITY

Hereby, electriQ declares that these air conditioners are in compliance with Directive 2014/53/EU. The full text of the EU declaration of conformity is available at the following internet addresses:

<https://www.electriq.co.uk/files/DOC/EU/iQool-C2MSC3PMS.pdf>

<https://www.electriq.co.uk/files/DOC/EU/iQool-C3MSC5PMS.pdf>

UK DECLARATION OF CONFORMITY

Hereby, electriQ declares that these air conditioners are in compliance with Radio Equipment Regulations 2017. The full text of the UK declaration of conformity is available at the following internet addresses:

<https://www.electriq.co.uk/files/DOC/UK/iQool-C2MSC3PMS.pdf>

<https://www.electriq.co.uk/files/DOC/UK/iQool-C3MSC5PMS.pdf>



Disposal: Do not dispose this product as unsorted municipal waste. Collection of such waste must be handled separately as special treatment is necessary.

Recycling facilities are now available for all customers at which you can deposit your old electrical products. Customers will be able to take any old electrical equipment to participating sites run by their local councils. Please remember that this equipment will be further handled during the recycling process, so please be considerate when depositing your equipment. Please contact the local council for details of your local household waste recycling centres.

SUPPORT

WARRANTY INFORMATION

electriQ guarantee provides cover against material or manufacturing faults. This means that if your air conditioner develops a fault within the first 2 years, we will arrange for it to be repaired or replaced*. We will also provide replacement parts within the first 5 years.

The system must be installed and annually serviced by an F-gas registered engineer. Evidence of this must be provided when the fault is logged with our technical team. Faults arising from installation errors and/or damage are specifically excluded.

Where we are unable to confirm that a fault is related to a manufacturing fault, we reserve the right to make a charge to cover the costs of an engineer visit to assess and repair the unit. This charge will be refunded in full if the fault is confirmed to be due to a manufacturing fault.

This unit must be operated under conditions as recommended in this user manual, at voltages indicated on the unit. Any attempts made to service or modify the unit by unqualified person, will render this WARRANTY VOID.

This warranty is in addition to, and does not affect, your statutory rights.

* A replacement may be offered where electriQ deem a repair not to be viable.

We recommend that you note the details of your purchase below and retain your original proof of purchase receipt with this manual. Keep these documents safe in the event of a warranty claim.

Purchase Date:	
Retailer name:	
Model number:	
Serial number:	
Installation Date:	
Installer name:	
Engineer/ Company name:	
Engineers Registration Number	
Service Dates	